

## Rollshutters

### MOTORIZED ROLLING SHUTTER (4" TO 10" BOX)

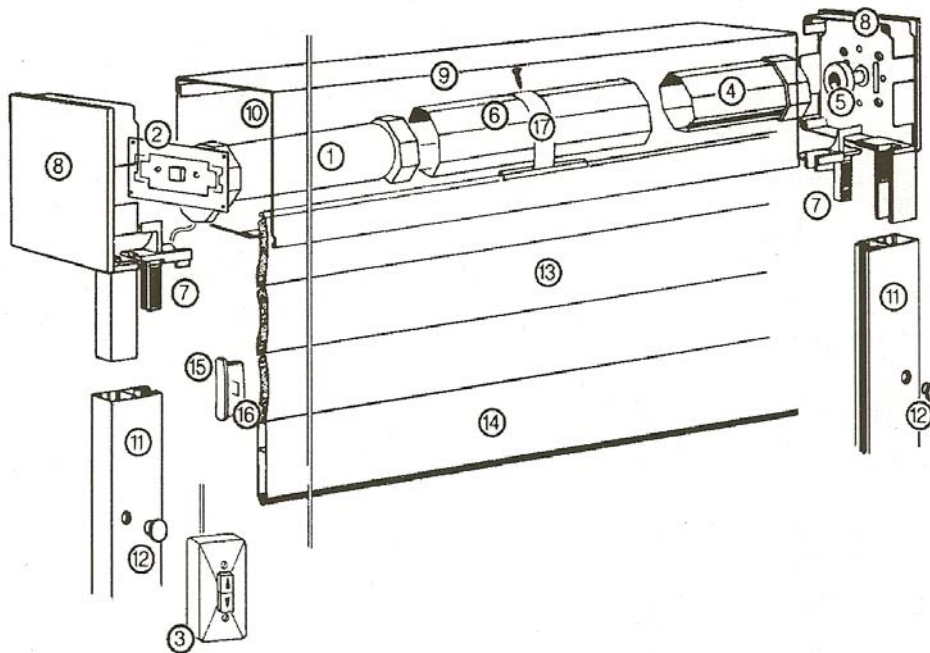

- |                   |                            |                           |
|-------------------|----------------------------|---------------------------|
| 1. TUBULAR MOTOR  | 7. ENTRY GUIDE             | 13. SLAT                  |
| 2. MOTOR BRACKET  | 8. END/SIDE CAP            | 14. BASE-SLAT             |
| 3. SWITCH         | 9. HOUSING (TOP/BACK)      | 15. SIDE-LOCKS (OPTIONAL) |
| 4. IDLER          | 10. HOUSING (FRONT/BOTTOM) | 16. STAPLES (RUST PROOF)  |
| 5. BALL-BEARING   | 11. SIDE-RAIL              | 17. SPRING-LOCK HANGER    |
| 6. OCTAGONAL AXLE | 12. PLUG BUTTONS           |                           |

AGR - RS 2